

# ZOOMLION

## CRAWLER SCISSOR LIFTS

### ZS0612C

Comply with CE Standard

#### HIGHLIGHTS

##### High Performance

- ▶ Rubber crawler for small ground pressure and great obstacle crossing ability
- ▶ Pivot steering with good maneuverability
- ▶ Simple single joystick control for steering and walking
- ▶ Click-to-level, simple to operate

##### Cost-Effectiveness

- ▶ Knuckles lubrication-free and maintenance-free
- ▶ AC motor full lifecycle maintenance-free
- ▶ Drawler battery tray, easy to maintain
- ▶ Emergency lifting arm, easy to service

##### Intelligent Connectivity

- ▶ Remote monitoring and rental system, easy to acquire machine info, efficient to run fleet

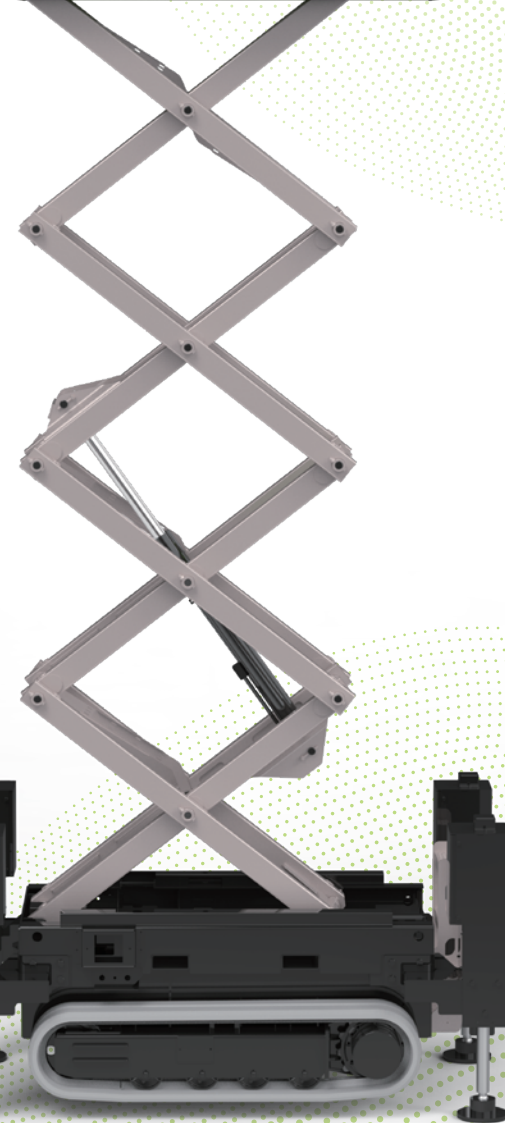
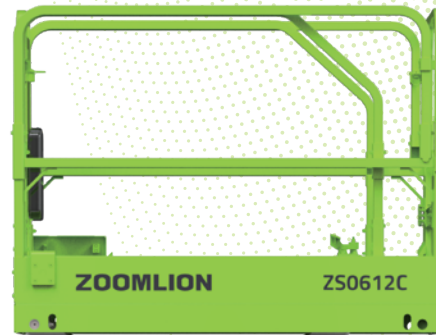

#### FEATURES

##### Standard Features

Proportional controls	Hour meter
All motion alarm	Extension deck (unidirectional)
Fold-down handrails	Charging protection system
Flashing beacon	Scissor maintenance prop
Self-closing entry gate	Forklift pockets
Load sensing system	AC power to platform

##### Accessories & Options

- ▶ Platform work lights
- ▶ Airline to platform
- ▶ Tool tray
- ▶ Anti-collision device

## ACCESS WITH ZOOMLION GREEN

Phone: 0086(731)-88353680 0086(731)-88250971  
E-mail: [awp@zoomlion.com](mailto:awp@zoomlion.com)

Add: 701 Xulong Nan Lu, Xiangjiang New District, Changsha Hunan, China  
Web: [www.zoomlion-access.com](http://www.zoomlion-access.com)

# MAIN SPECS OF CRAWLER SCSSIOR LIFTS ZS0612C

Comply with CE Standard

Model	ZS0612C	
	Imperial	Metric
<b>Size</b>		
Work Height	25ft 7in	7.8m
A Platform Height-Elevated	19ft	5.8m
B Platform Height-Stowed	3ft 8in	1.13m
C Platform Length	5ft 5in	1.65m
D Platform Width	2ft 5in	0.74m
Platform Extension	2ft 11in	0.9m
E Overall Height (Rails Up)	7ft 5in	2.27m
Overall Height (Rails Down)	6ft 2in	1.88m
F Overall Length	7ft 2in	2.19m
G Overall Width	3ft 9in	1.15m
H Ground Clearance	3in	0.08m
<b>Performance</b>		
Platform Capacity	510lb	230kg
Capacity on Deck Extension	250lb	113kg
Max. Number of Workers	2 (outdoor)	
Drive Speed (Stowed)	1.25mph	2km/h
Drive Speed (Raised)	0km/h	0km/h
Turning Radius	0in	0m
Drive Motor	24V/2×2KW	
Up/Down Time	20/24s	
Gradeability	30% (17°)	
Max. Working Slope (Lateral/Vertical)	12°/7°	
Drive	Rear Wheels	
Brake	Rear Wheels	
<b>Power</b>		
Battery	4×12V/240Ah	
Charger	24V/30A	
<b>Weight</b>		
Gross	4012lb	1820kg

